

Helmstar **OWNER'S MANUAL**

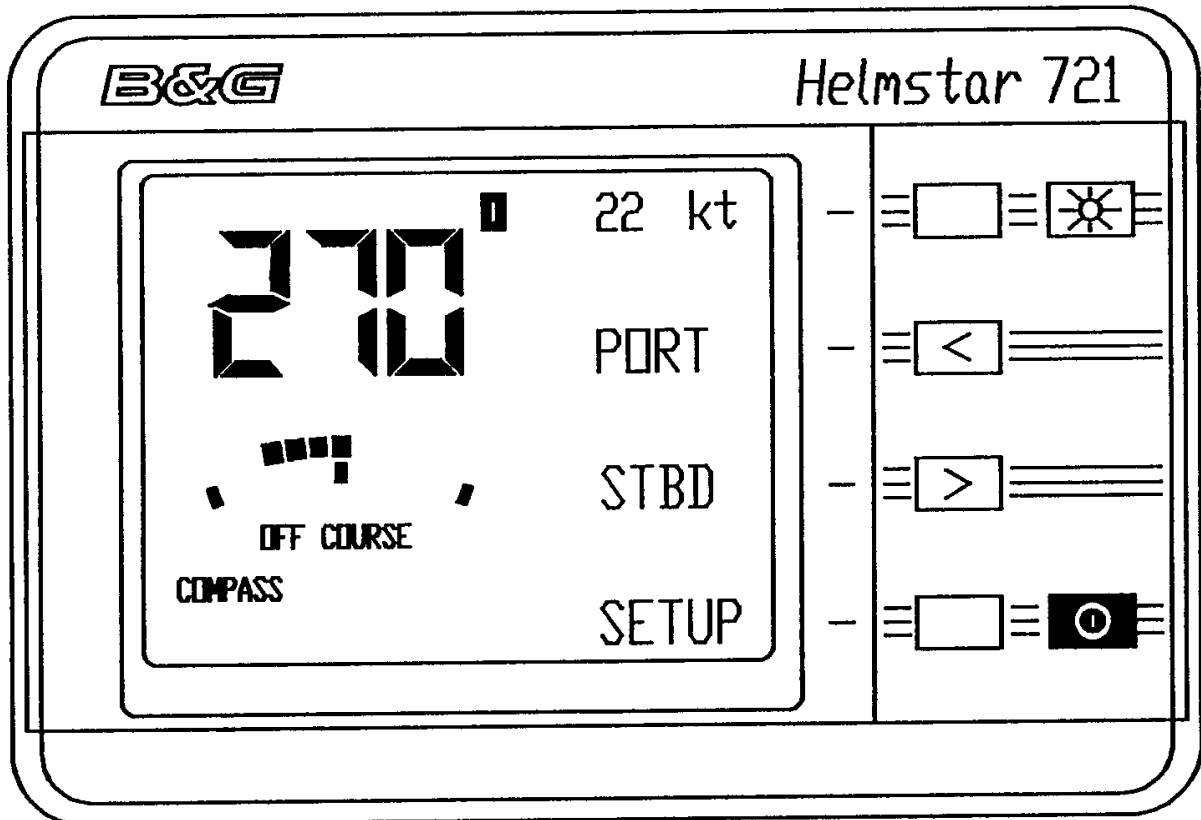

© Copyright Brookes & Gatehouse Limited, 1989

All rights reserved including right of reproduction in whole or in part, in any form.

CONTENTS

Introduction	ii
Using an autopilot	ii
1 YOUR HELMSTAR	1.1
System block diagram	1.2
1.1 Control keys	1.3
1.2 Display	1.3
2 OPERATING MODES	2.1
3 HELMSTAR OPERATION	3.1
3.1 Steer to compass	3.2
3.1.1 Changing course	3.2
3.2 Steer to NMEA	3.3
3.3 Parameters	3.4
3.3.1 Steering mode	3.4
3.3.2 Boat speed/manual input	3.5
3.3.3 Boat speed/cross track error	3.6
3.4 Alarms	3.6
3.4.1 Setting an alarm	3.7
3.4.2 Setting a battery alarm	3.8
3.4.3 Setting an NMEA alarm	3.8
3.5 Hand Held Unit	3.9
4 FAULT MENUS	4.1
4.1 Fault example	4.1
4.2 System malfunctions	4.1
Helmstar error menus	4.2
5 FAULTFINDING	5.1
6 COMMISSIONING	6/7.1
7 INSTALLATION	6/7.1
APPENDIX A - WARNINGS	A1

INTRODUCTION

It is important for the safe and efficient operation of your *HELMSTAR* system that you read this manual carefully before operation.

Operational Limitations

Helmstar has been designed to be simple to use, while maintaining sophisticated features. It does not have any knobs associated with most autopilots, instead the system is commissioned by an authorized *B&G* agent, who will input boat information to the display unit. It is very important that the figures fed to the autopilot are not changed. If you stray into the commissioning menu, please press the OFF key to return you to normal operation. If these numbers are changed by anyone but an authorized *B&G* agent, your warranty may be invalidated.

Warranty Limitations

Helmstar should not be used until it is commissioned. Please read Appendix A for more information.

Helmstar is guaranteed for three years when;

- The entire installation has been inspected and approved by an authorized *B&G* agent and a warranty certificate issued for that installation.

- Any change to the installation must be re-approved as above.

- Tampering with any of the components of the system may invalidate the warranty.

- Your warranty certificate has been returned.

USING AN AUTOPILOT

Having a good autopilot is like having an extra member of crew on board, a crew that never sleeps and always steers an excellent course.

You can use Helmstar in four ways.

The simplest is to steer the boat in the direction you want to go and press COMP on the autopilot. It senses the direction from an electronic compass and holds that course until told otherwise.

Steer to NMEA is possible if your craft has a navigation aid with NMEA 180 output.

A power steer mode is also available and allows you to steer port, starboard or midships with a single button press.

Behind Helmstar's operational simplicity are some very sophisticated features. The first of these is the adaptive programme which enables Helmstar to learn about the boat's steering characteristics in the prevailing sea conditions and adjust its operation accordingly.

In steer to compass mode, it always aims to reduce the cross track error to zero in a set number of boat lengths resulting in much improved course keeping over other pilots.

1 YOUR HELMSTAR

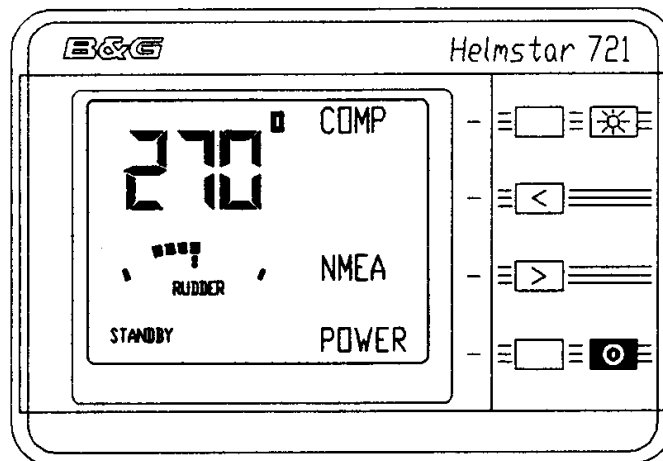

HELMSTAR is a computer based autopilot system which is customised to the vessel in which it is installed. Information about the boat is fed into the pilot on commissioning. This includes rudder limit positions, length of the craft, displacement, keel type etc. and allows the pilot to be tailored to any craft.

Helmstar is also an adaptive autopilot and is able to learn about the boat's steering characteristics in the prevailing sea conditions. This enables the pilot to automatically adjust its operation. To reduce power consumption on long journeys, three modes of operation are provided (see Section 3. PARAMETERS).

Features available include:

- Steer to compass
- Steer to NMEA
- Power steer
- Alarms (5 types)
- 3 operating modes - fine, normal, economy.

Helmstar 721 System Block Diagram

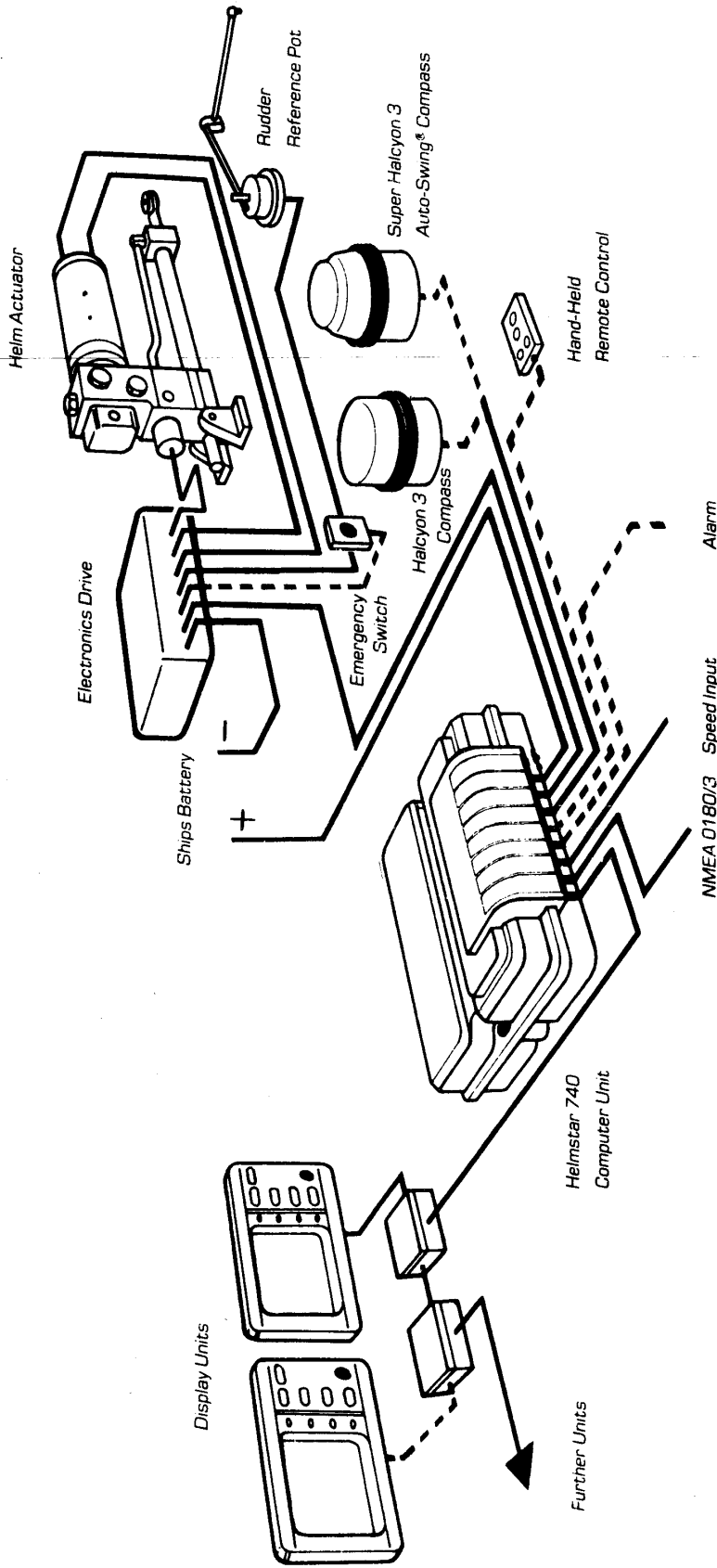

1.1 Control Keys

The Helmstar display has 6 keys, two are dedicated and the other four are multifunction.

!!! please note : pressing the 'off' key will place the pilot in standby mode at any time.

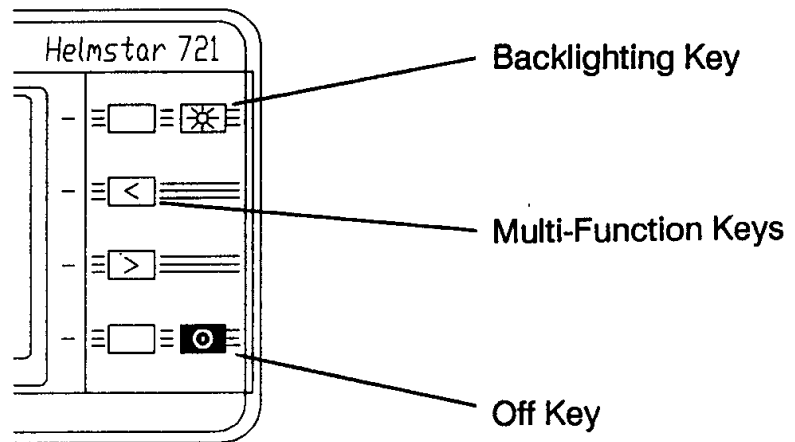

-The OFF key. This key can be pressed at any time to switch control back to manual steering and display the standby menu. Repeated pressing of this button toggles between command and standby mode (see operating menu tree).

-Back Illumination Key. This key can set the level of display lighting in four stages - OFF, DIM, MEDIUM OR BRIGHT.

-Multi-function keys. The four multi-function keys relate to the menus displayed adjacent to them. To select a function, simply press the adjacent key.

1.2 Display

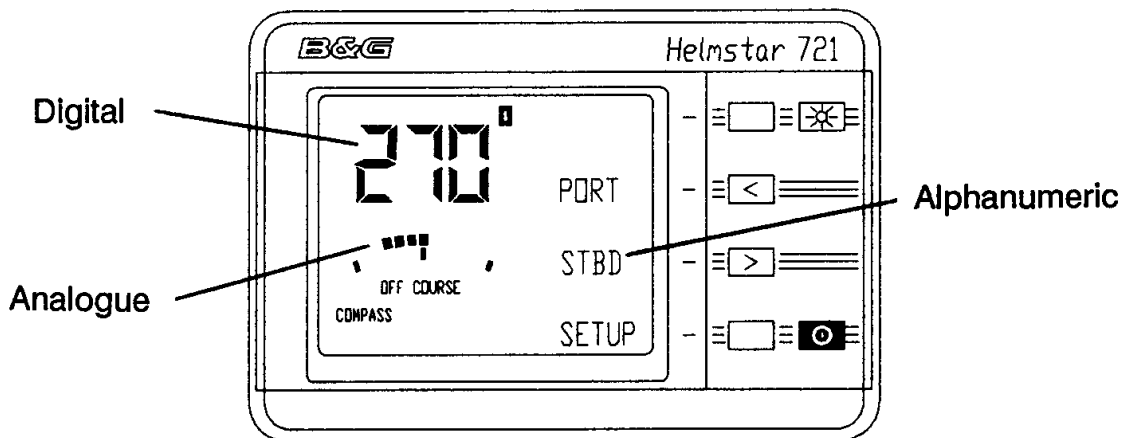

Helmstar has a special liquid crystal display with analogue, digital and alphanumeric sections.

- Analogue. The bar graph and associated text are used to indicate rudder position, course error and pilot status.

Associated text:

- OFF COURSE, RUDDER
- STANDBY, COMPASS, POWER, NMEA
- ALARM, SET, WATCH
- Digital. The digital display consists of three seven segment digits positioned over the analogue display. This is used to display heading and course.
- Alphanumeric. The alphanumeric display is used to display menus and some numeric values. These consist of four lines that are placed adjacent to the multi-function keys.

2 OPERATING MODES

There are two basic operating modes for Helmstar:

- STANDBY
- PILOT

Please refer to the Operating menu tree for details.

In standby mode, steering is under MANUAL control. The pilot is powered up and acting as a compass repeater. The analogue meter shows rudder position and the legends display RUDDER (for analogue) and STANDBY (for mode).

In pilot mode, steering is under PILOT control. To engage Helmstar simply press the required mode on the displayed COMMAND menu, eg., press the COMP key to steer to compass.

When the unit is switched on, the COMMAND menu is displayed. From this, the pilot can be directly engaged to a compass or NMEA course or can be put in power steer mode. If you press the OFF key, the STANDBY menu will be displayed. This allows you to go back to the pilot command menu (press PILOT) or go to the SETUP menu (press SETUP). Pressing the setup key will allow changes to be made to parameters, alarms or heading.

If you get into any difficulty when operating the system, press the OFF key. This will disengage the pilot and put you back in the command menu where you can try again.

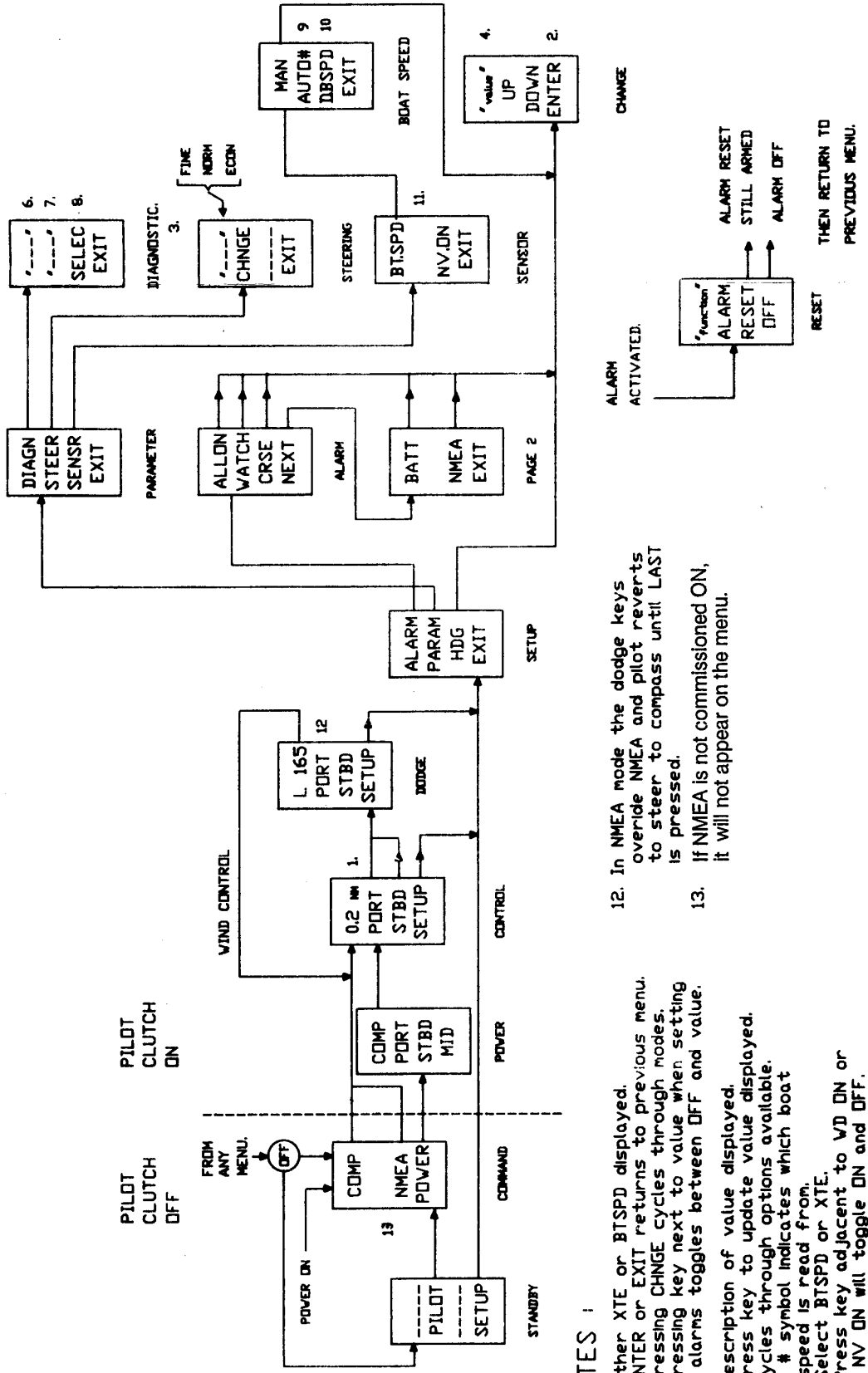

NOTES :

1. Either XTE or BTSPD displayed.
2. ENTER or EXIT returns to previous menu.
3. Pressing CHNGE cycles through modes.
4. Pressing key next to value when setting alarms toggles between OFF and value.
6. Description of value displayed.
7. Press key to update value displayed.
8. Cycles through options available.
9. A # symbol indicates which boat speed is read from.
10. Select BTSPD or XTE.
11. Press key adjacent to WD ON or NV ON will toggle ON and OFF.
12. In NMEA mode the dodge keys override NMEA and pilot reverts to steer to compass until LAST is pressed.
13. If NMEA is not commissioned ON, it will not appear on the menu.

3.1 Steer to Compass

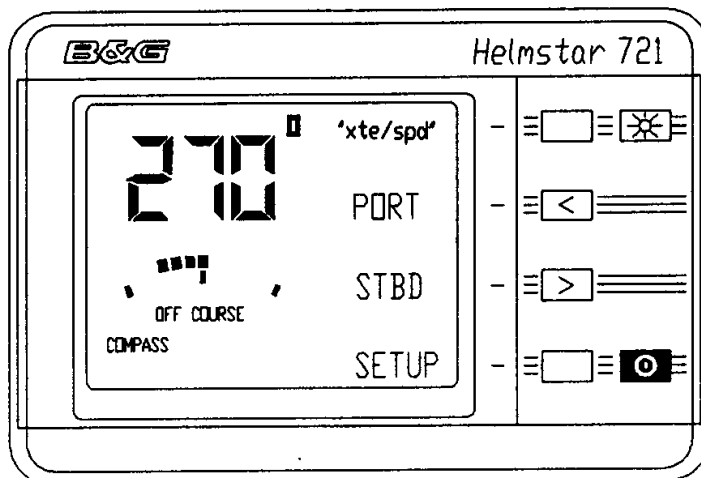

When Helmstar is switched on, the COMMAND menu is displayed. Pressing the COMP key will engage the pilot on the current course as displayed on the digital display. The 'compass' legend will be displayed and the analogue meter will indicate OFF COURSE error.

After pressing the COMP key the menu will change. This menu is called the CONTROL level and displays either cross track error (N) or boat speed (KT) in the top line. The two middle keys are dodge keys which dodge 10 degrees per key press, and the lower key allows you to go to set up menus.

To gain manual control at any time press the OFF key.

3.1.1 Changing Course

When steering to compass there are three ways of changing course.

- Press the OFF key to gain manual control, then steer to your new heading and press the COMP key to engage the pilot and maintain that course.
- Pressing either of the dodge keys will cause a ten degree deviation. Press LAST to resume previous course.
- To change course under pilot control press SETUP in the control menu and then press HDG in the setup menu. The change menu displays the heading on the top line. To change heading use the UP/DOWN keys to select the course desired and press the ENTER key. The pilot will steer to the new course and the control menu will reappear.

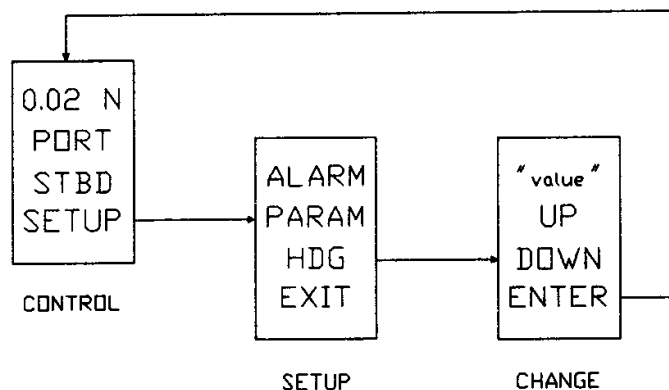

To select a heading on power up, press the OFF key to get to standby mode, then press SETUP as above.

When in steer to compass mode, the top line of the menu can be programmed to show either cross track error (xte) in nautical miles, or boat speed (btspd) in knots (see parameters).

3.2 Steer to NMEA

If the steer to NMEA facility is required, then a suitable position fixer must be fitted. Helmstar must be told which NMEA sentence to respond to when it is commissioned.

At the present time, Helmstar uses NMEA 180 data from a suitable position fixer. NMEA 183 will be available in due course. Boats fitted with B & G Navaid or Hercules can translate NMEA 183 data into NMEA 180 data (see appropriate handbooks).

In steer to NMEA mode, Helmstar uses cross track error information from the position fixer to calculate which course to steer to bring the boat back onto the desired track. Helmstar will then hold the boat on track even in the presence of cross tides.

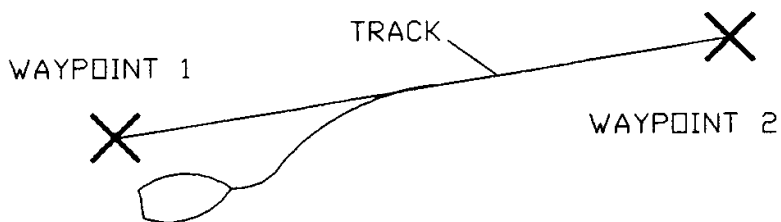

Two waypoints must be entered, the first usually being the current position and the second is the required destination. The line between these two points is the track and the information given to the pilot from the position fixer is the distance from this track.

!!! Please Note: Helmstar relies on information from the position fixer. If the position fixer is not operated correctly, the autopilot could give unexpected course changes.

If the boat is not near the track (approx. 0.3 nautical miles) and pointing in the right direction when NMEA is selected, LARGE COURSE CHANGES may result as Helmstar brings the boat onto the desired track. It is, therefore, recommended that NMEA is only selected when the boat is near the track and pointing in approximately the correct direction.

An NMEA alarm is available to warn if the target course changes by more than a specified amount.

3.3 Parameters

Helmstar constantly monitors the seastate and makes alterations automatically to its own set of control parameters. There are some parameters which can be changed by the user, these include:

- Steering mode
- Boat speed/manual input select
- Boat speed/cross track error display

3.3.1 Steering Mode

To allow Helmstar to be as flexible as possible, the user can select the performance required. There are three operating modes which trade course keeping against battery power used. Obviously, if a good course is required, the rudder will be moved constantly to keep the heading error small and the motor will consume more power. If however, you are sailing any great distance, it makes sense that a wider course error (not cross track error) could be tolerated to save battery power.

The three modes are:

- FINE This will hold a tight course.
- NORM This mode will be for normal conditions.
- ECON This is the economy mode and will use minimum battery power to hold course.

It should be noted that the pilot may override these controls. If, for instance, it is doing a turn in economy mode, it will automatically switch into FINE to manoeuvre the turn correctly.

To select the mode required, press SETUP in any menu and then press PARAM in the setup menu and then STEER in the parameter menu. The steering menu allows the mode to be selected by pressing the CHANGE key. Press CHNGE to cycle the top line through the modes. The current mode will be displayed on the top line. Press the EXIT key when finished.

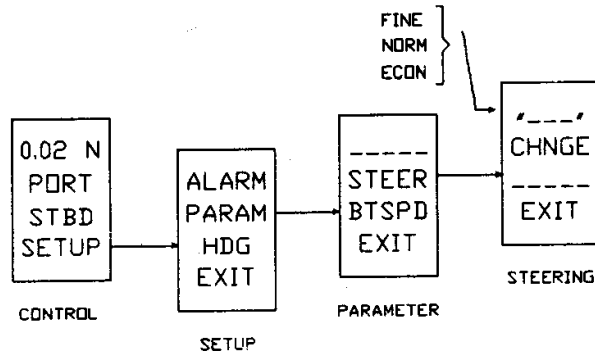

3.3.2 Boat Speed/Manual Input

The pilot MUST have some boat speed information in order to optimise the pilots performance. If the sensor malfunctions for any reason, the pilot will continue to steer by using a default boatspeed. To change the boatspeed, press the OFF key and enter a manual boatspeed. To solve this type of problem the speed can be entered by hand. This will affect the performance slightly, but not too noticeably. In these circumstances, the average speed should be entered as follows:

Press SETUP in any mode and press PARAM in the setup menu. Press the BTSPD key to get to the speed menu and select MAN to get to the change menu. Use the up/down keys to select the required value and press the ENTER key.

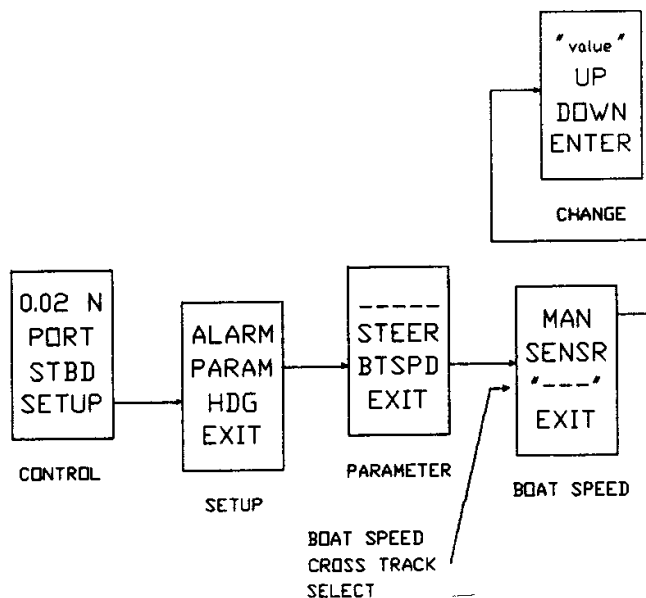

To change back to the boat speed sensor press SENSR in the speed menu.

3.3.3 Boat Speed/Cross Track Error

When under pilot control the normal menu being displayed will be the COMMAND menu. The top line of this display can show either boat speed or cross track error. The units are Knots for boat speed and Nautical miles for cross track error. The pilot will reduce the cross track error (dead reckoned) to zero in a preset number of boat lengths, so this will normally read zero.

To choose which is displayed, press SETUP in any menu and press PARAM to get to the SETUP menu. Now press BTSPD to show the boatspeed menu. The third key toggles between the two choices. The name displayed in this menu is the one NOT displayed in the command menu. Press EXIT when finished.

3.4 Alarms

There are five types of alarm available on Helmstar, all of which cause an external alarm to sound when fitted.

The Watch alarm causes the display to show an alarm reset menu immediately, and will sound the audible device if the alarm is not reset within sixty seconds.

The Battery and Course alarms will not generate an alarm until the error has occurred continuously for thirty seconds. The reset menu will then appear and the audible device will sound.

The alarms available are:

- WATCH. This a time keeping function which is activated after the period set, eg., 10 mins (press RESET and it will be activated again after 10 minutes).

The units are hours & minutes (max 12 hours). NOTE: this only displays the time set, it is not a countdown timer.

- CRSE. This is an off course alarm which can be set (in degrees) to the maximum allowable deviation from heading, normally 15° - 20° (max 60 degrees).
- BATT. This is a battery low level alarm which is factory set at 10.5 Volts (12V system). It can be set at any level, eg., 22V for a 24V system (max value 40V).
- NMEA. This indicates that a course change has occurred (default value 15 degrees).

It is advisable that an alarm is fitted wherever an autopilot is in use. As well as the above features, any fault will also sound the alarm. A suitable message will appear on the display unit.

When an alarm goes off, the display will report which alarm is active. The audible device will be turned on immediately (except for the watch alarm. This will only sound after a period of sixty seconds if the alarm is not reset/cancelled).

Each alarm can be disabled by pressing either the OFF key or the RESET key, in the alarm menu. Pressing the RESET key will cause the alarm to be raised again if the cause still exists. Press the OFF key to cancel the alarm.

When setting an alarm value, the top line of the change menu will display either the value currently entered or 'OFF'. If this displays 'OFF' the alarm is disabled. To set the alarm, press the key next to this and the value will reappear. The value can also be changed by using the up/down keys as usual.

3.4.1 Setting an Alarm

To set an alarm, press SETUP from any menu. Choose ALARM in the setup menu and the first alarm menu is displayed. This allows access to ALLON, WATCH and CRSE alarms.

If the ALLON (all alarms on) key is pressed, all the alarms are enabled and the display remains unchanged. NOTE: To enable one alarm only then use WATCH, CRSE or BATT.

If WATCH is pressed, the change menu appears and allows the time value to be changed using the UP/DOWN keys. The units are in hours and minutes.

To disable the alarm, press the key adjacent to the value and OFF will be displayed.

If CRSE is pressed, the change menu appears and the value displayed shows the deviation (in degrees). To change this value, use the UP/DOWN keys as usual. To disable the alarm, press the key adjacent to the value and OFF will be displayed.

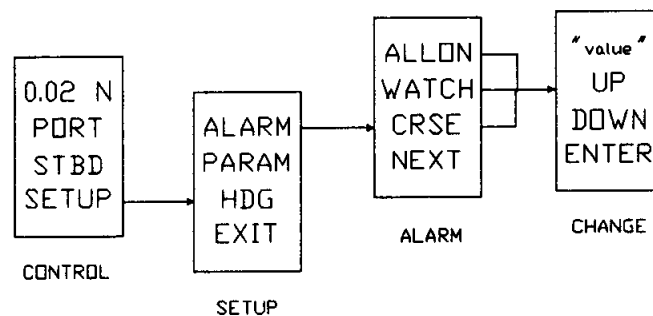

3.4.2 Setting a Battery Alarm

To set a battery alarm (from the alarm menu), press NEXT and page 2 of the alarm menu will be displayed. Press BATT to get to the change menu.

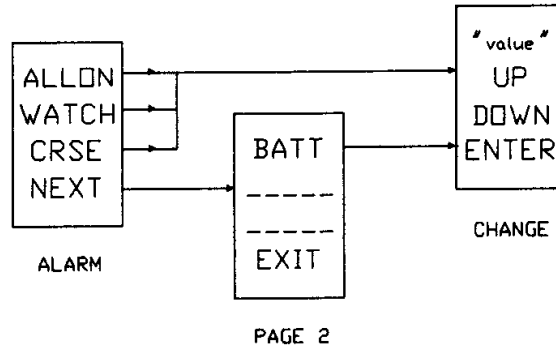

The value shown is the alarm voltage previously set. To change the value use the UP/DOWN keys. Press the enter key when finished. The alarm can be disabled by pressing the key adjacent to the value.

When an alarm has been set and the ENTER key is pressed, the setup menu will reappear. Press EXIT to return to the control menu.

3.4.3 Setting an NMEA Alarm

From page 2 of the alarm menu, press NMEA. The CHANGE menu will appear and the top line of the alphanumeric display will show the current course deviation in degrees, before the alarm is activated. To alter this value, use the UP / DOWN keys and press ENTER when the required value is displayed. Press EXIT to return to the CONTROL menu.

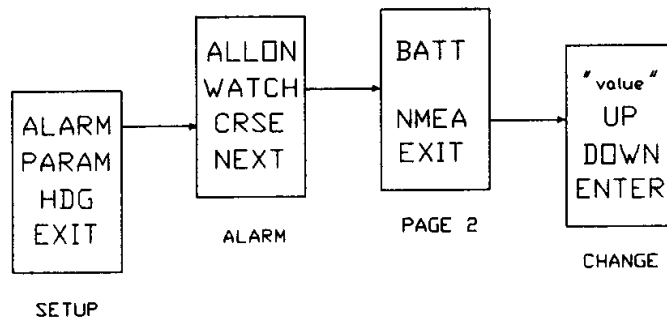

3.5 Hand Held Unit

Using the Hand Held Controller, the helmsman is able to easily enter course changes or dodge round obstacles.

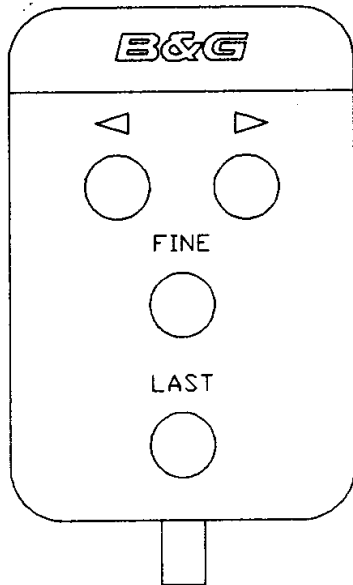

Pressing the PORT or STBD keys gives a 10 degree dodge.

Pressing the FINE key, followed by the PORT or STBD key, gives a 1 degree course change.

Pressing the LAST key will resume the original course before a 'dodge' was entered.

Note the distinction between 'dodging' and 'changing course'. When a 'dodge' is entered, the previous course is remembered and can be resumed, whereas when a 'course change' is made, the previous course is not remembered.

The Hand Held Controller only operates when Helmstar is engaged, ie., it does nothing in the STANDBY mode.

4 FAULT MENUS

When Helmstar is commissioned it interrogates the entire navigation system and commits all information to memory. When Helmstar is subsequently turned on, it expects the same equipment to be connected and switched on. If the equipment is not functioning as expected, Helmstar will display an error message, disengage the pilot and sound the alarm.

4.1 Fault Example

The pilot has detected the boat speed sensor is giving a very low reading. If a major fault occurs, the pilot immediately disengages and displays an error message. An audible alarm will sound, where fitted. If the boatspeed sensor fails, an error message is displayed and the pilot will use the default speed to continue steering. If the masthead unit fails, then Helmstar will revert to steering to compass. The same will happen if an NMEA fault occurs. Press the OFF key to reset the error, and investigate the cause of the error. For example, the most probable cause will be weed on the sensor. Note that if the real boat speed falls below 0.5 knots, the same message will be displayed.

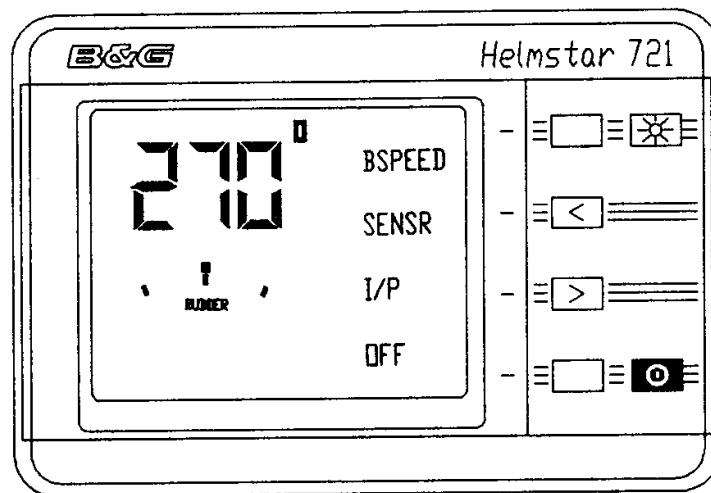

4.2 System Malfunctions

Pilot Stop Switch

This is supplied as an option with Helmstar, and it is strongly advised that one is fitted. This switch when pressed totally isolates the drive unit so that manual control is returned. It should be positioned for easy access so that, in an emergency situation, it can be pressed to override the pilot. To re-engage the pilot press the button again (note the pilot will probably display an error message as it has lost control, so press the OFF key to reset).

Malfunctions

Helmstar is capable of self diagnosis in the event of a hardware malfunction. An error message will be displayed to identify the cause. Please refer to the faultfinding menus. Any fault will disengage the pilot. If a total system failure occurs and locks the pilot in the control mode, either press the STOP switch or turn the pilot off from the battery.

If you cannot find the problem contact your nearest *B&G* agent for help.

Helmstar 721 Error Menus

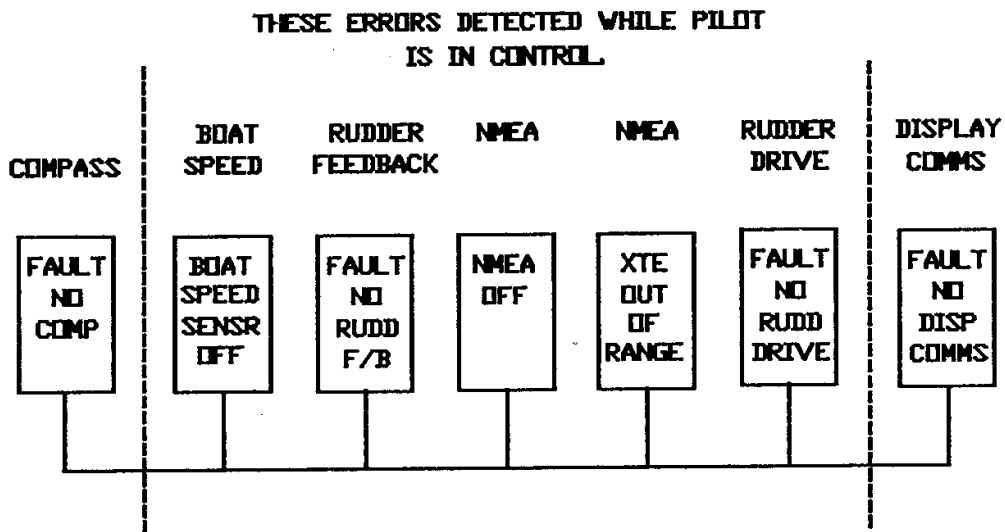

PRESS 'OFF' TO RESET ERROR,
DEACTIVATE ALARM AND
RETURN TO COMMAND MENU.

COMP
NMEA
POWER

5 FAULT FINDING

This page will describe how to interpret an error message (see error menus). Seven error menus exist, three of these will only report a fault while the pilot is in control mode.

1. Fault no comp

This is displayed when either the power line to the compass has been broken or one of the signal lines is disconnected.

Check the cable from the compass to the processor unit.

2. Fault no disp comms

This is displayed if the messages sent from the display to the processor are garbled. This may be caused by an VHF/SSB when transmitting or some other very noisy source.

Check cable from display to processor and make sure screen is connected.

3. Fault no boat speed

This is detected when the boatspeed is less than 0.5 knots and the pilot is trying to steer.

Check sensor is not jammed.

Check cable to processor unit.

If sensor is faulty, use manual boat speed to continue to use pilot (see 3.3.2). This is really a 'get you home' function and the sensor should be fixed as soon as possible.

4. Fault No Rudd F/B.

This occurs if the pilot reads a value from the rudder reference unit which is outside the commissioned value.

Check the cable is connected and is not fouled by the steering gear.

Check the linkage.

Has the unit been commissioned?

5. Fault no rudd drive

This occurs if the pilot has asked the rudder to move, but in 20 seconds no rudder movement has been detected.

Check the stop switch has not been left off.

Check power to drive unit is on (eg, circuit breaker).

Check drive unit fuse. If blown, is check wiring before operation.

Check cabling.

6. XTE out of range

This is displayed if you are too far off track (approx. 0.3 NM) for the pilot to operate correctly.

7. NMEA comms input off

This message appears if the signal from the position fixer is lost.

NOTE: See *B&G* agent if above checks do not solve the fault.

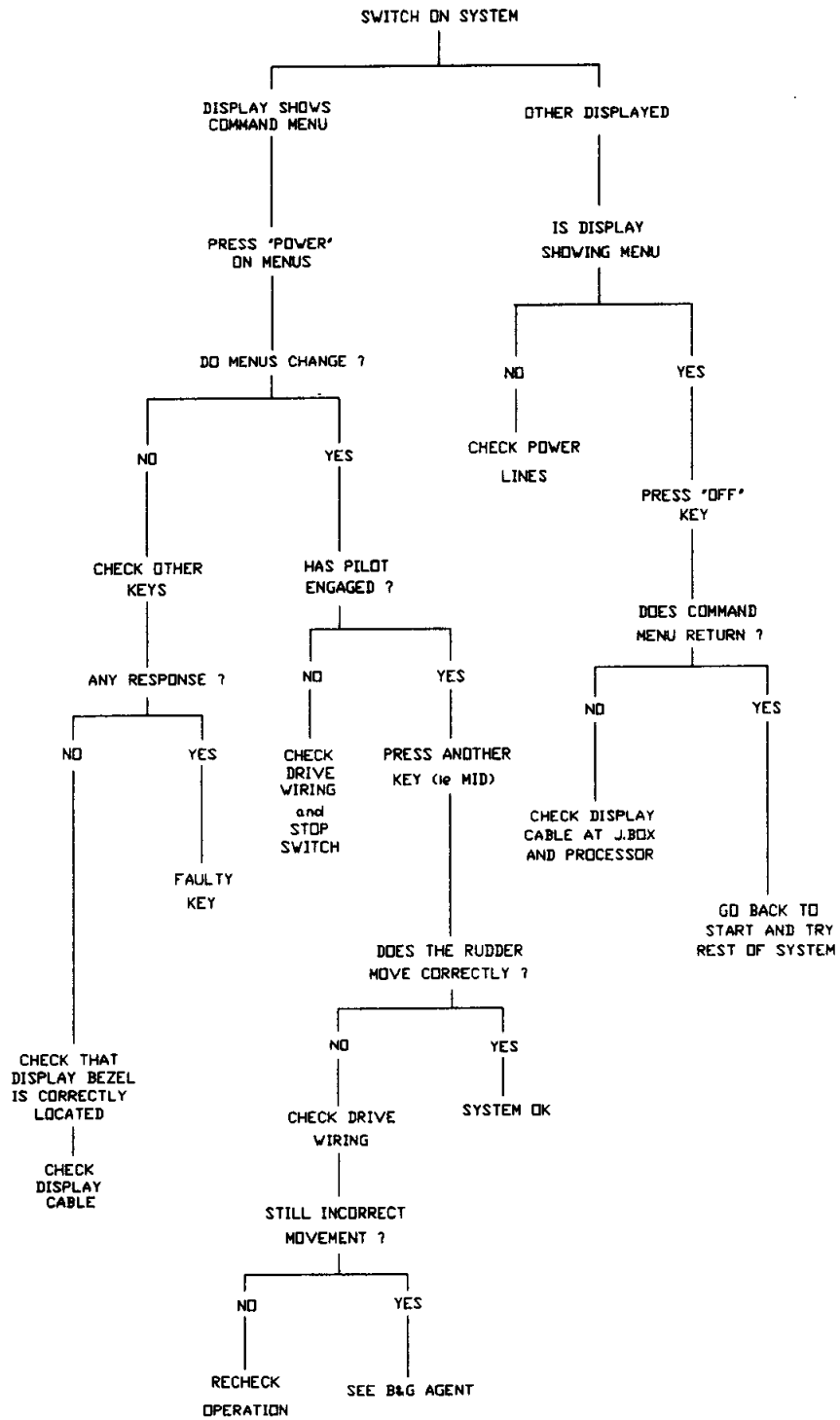

Chart 1 - Troubleshooting System

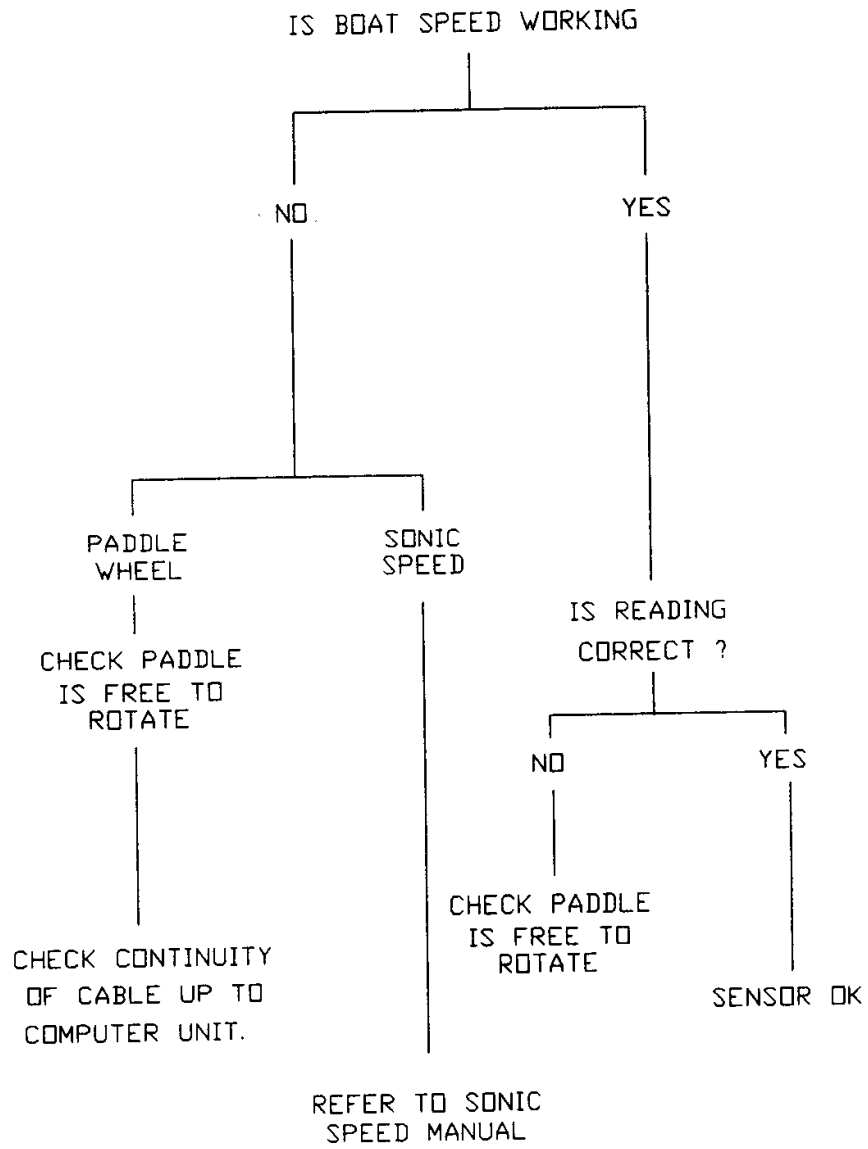
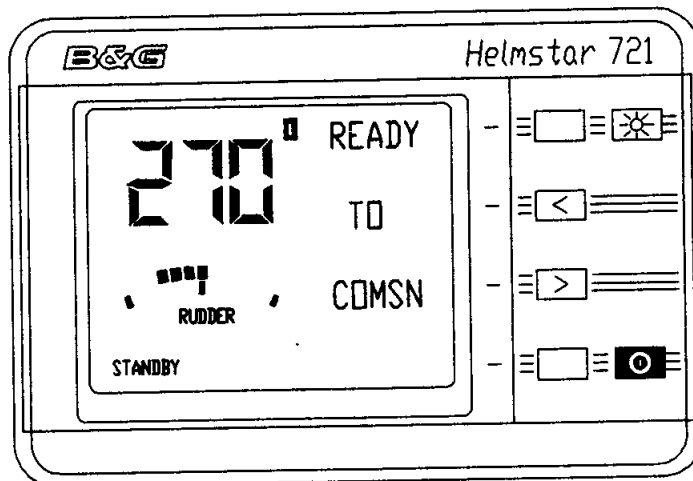

Chart 2 - Troubleshooting Boatspeed/Log

6 COMMISSIONING

When Helmstar is first powered-up, the display will show the following message:



The display unit will not function until Helmstar has been commissioned by an authorised *B&G* agent.

7 INSTALLATION

1. Cables and equipment should be placed at least 1 metre from VHF transmitters, and twice that distance from SSB transmitters.
2. The processor box should be mounted below decks in a cool and dry place. This unit is waterproof but cables should be kept dry for maximum life.
3. Do not site equipment too close to the engine.
4. The drive electronics should be sited as close to the autopilot motor as practical.
5. If drive power cables require extending, they should be increased by 1 square mm for every metre of extra cable (4 square mm is supplied).

APPENDIX A - WARNINGS

As already mentioned, Helmstar should not be operated until it has been commissioned by an authorised *B&G* agent. This is because the rudder limit positions have not been setup and damage could result if operated by an inexperienced user.

HELMSTAR WILL CONTROL YOUR CRAFT IN A SAFE MANNER PROVIDING IT IS OPERATED IN ACCORDANCE WITH THE INSTRUCTIONS HEREIN. DEVIATIONS FROM THE STATED PROCEDURES CAN ENDANGER LIFE AND CAUSE DAMAGE TO EQUIPMENT.

BROOKES AND GATEHOUSE LIMITED CANNOT BE HELD RESPONSIBLE FOR ANY PERSONAL INJURY OR DAMAGE TO VESSELS OR EQUIPMENT HOWEVER CAUSED, WHERE HELMSTAR IS IN USE.

Rule 5 International Regulations for preventing collisions at sea (1972) states:

Every vessel shall at all times maintain a proper lookout by sight and hearing as well as by all available means appropriate in the prevailing circumstances and conditions so as to make a full appraisal of the situation and of the risk of collision.